



multi-link inc.
expanding global communications

VERSA-LINK™ ATX-250

Call Processor

Owner's Manual

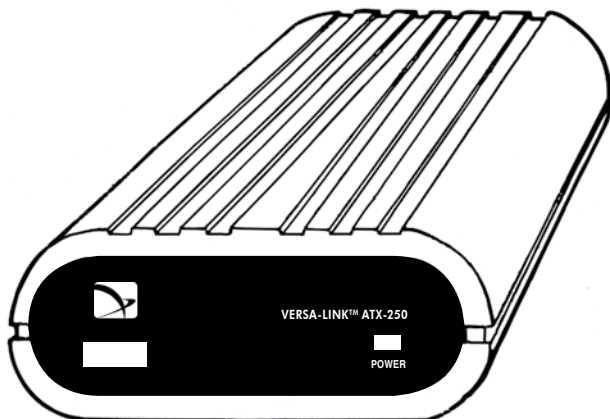

VERSA-LINK™ ATX-250

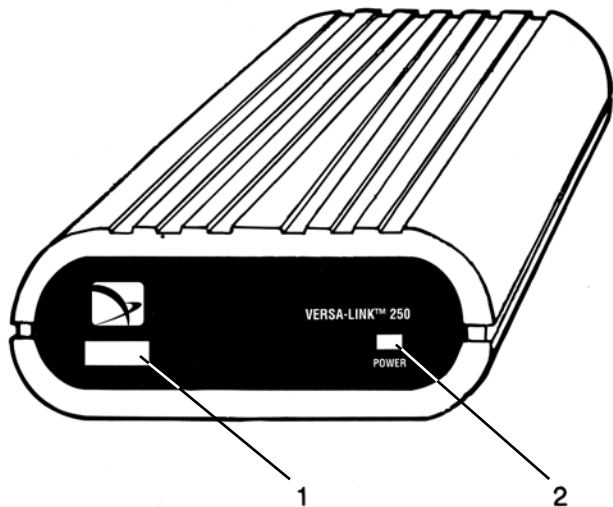

(1) DIP SWITCHES (2) POWER ON INDICATOR

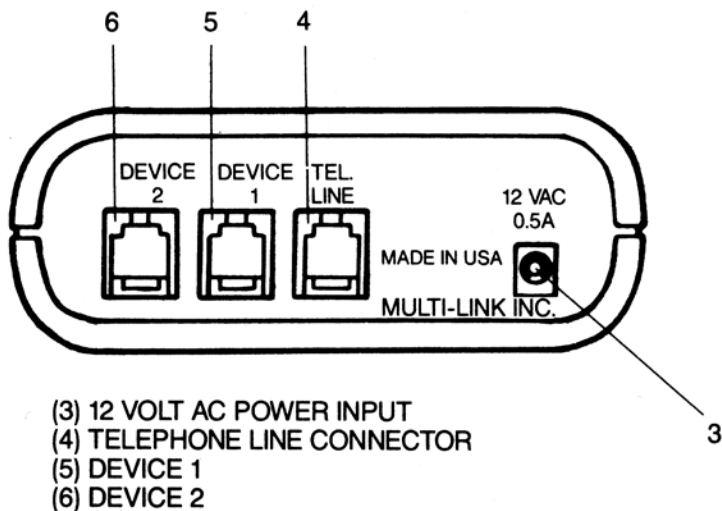

(3) 12 VOLT AC POWER INPUT
(4) TELEPHONE LINE CONNECTOR
(5) DEVICE 1
(6) DEVICE 2

ATX-250 OPERATING MANUAL

TABLE OF CONTENTS

Page

1. INTRODUCTION	2
Basic Features / Call Processing	
2. EQUIPMENT	4
FAX Machines / MODEMS / Telephones and multi-line systems / Other equipment	
3. APPLICATIONS	7
Adding FAX or MODEM to a voice line / Expanding a FAX line / Allowing two data devices to share one line	
4. OPERATION	9
Outbound calls / Manual transfer / Automatic FAX transfer / CALL OPTI-MIZER	
5. INSTALLATION	13
Your phone line / Telephone systems / Multi-line phones / Attaching FAX and data devices	
6. USER SELECTABLE FEATURES	18
Configuration switches / Device selection codes / Factory settings	
COMMONLY ASKED QUESTIONS	22

APPENDICES

A. FCC INFORMATION & LIMITED WARRANTY	23
B. TECHNICAL SPECIFICATIONS & SERVICE INFORMATION	24

INTRODUCTION



INTRODUCTION TO THE WORLD OF CALL PROCESSING

Your Versa-Link ATX-250 is a powerful Computerized Call Processor that allows more than one telephone device to share a single phone line. Versa-Link is compatible with standard telecommunication and office equipment including: Facsimile (FAX) machines, computer MODEMS, PC FAX Boards, single and multi-line telephone systems, answering machines, phone mail systems, credit approval systems, and loop start TELEX equipment.

Versa-Link allows you to expand your present communications network without installing an expensive dedicated phone line for each device. Versa-Link provides for greater utilization of phone lines and office equipment.

1.1 BASIC FEATURES

Versa-Link is a 24-hour communications control center that automatically analyzes and routes incoming calls to the proper equipment. Your Versa-Link ATX-250 permits a caller to remotely access your telephone, FAX machine, computer MODEM, or other equipment you may have attached. Standard features include: – **Auto FAX Detection** – **CALL OPTI-MIZER** – **Automatic Ring-through to your most-used equipment** – **Manual Transfer** – **Calling Party Hang Up Detect.**

CALL OPTI-MIZER is a unique feature that makes your phone line look more like a dedicated voice line to voice callers, and more like a dedicated data line to FAX or computer MODEM callers.

Calls can be manually transferred at any time by either the caller or the called party.

Versa-Link's data protection feature allows you to transmit FAX or computer MODEM data without the fear of someone disturbing the transmission by picking up an extension phone. It also gives you peace of mind knowing that your voice call will never be interrupted by a FAX or MODEM.

Another unique feature is Versa-Link's surge suppressor, which provides added protection from lightning strikes a voltage surges that could damage your sensitive communications equipment.

INTRODUCTION

1.2 CALL PROCESSING

Call processing is the task of routing telephone voice and data calls to one of several destinations. Your phone company can be considered a very large call processor.

To better understand the principles behind call processing, consider the following example:

- A receptionist who answers all incoming calls (in this case, the Versa-Link ATX-250)
- A Customer Service Agent.
- A sales agent.

When a phone call comes in, the Versa-Link acts as a receptionist and answers the call. If the caller requests the sales agent by dialing an access code, the Versa-Link will transfer the call without disturbing anyone else. If no code is dialed, the call is automatically directed to the customer service agent for information and further routing. The customer service agent may re-direct calls to the sales agent by entering the proper access code.

Your ATX-250 can be used to process calls to your voice and data equipment, just as it did in the above example. If you are adding FAX or a computer MODEM to a voice line, you have:

- A Versa-Link ATX-250 that answers all calls and transfers them to the proper device.
- A telephone system that handles most calls.
- A FAX machine or a computer MODEM.

This is just one application. As you will see, your Versa-Link is not just a switch. It's a very smart call processor that does exactly what it's told to do, and does it very well.

Your Versa-Link ATX-250 is compatible with virtually all modern telecommunications equipment, including single and multi-line telephones. Because your ATX-250 is installed between your telephone system and the phone company, it can direct all your telephone traffic to the proper equipment. The most popular types of equipment used with a Versa-Link ATX-250 are described below.

2.1 FAX MACHINES

Your ATX-250 has special features that work extremely well with FAX machines and PC FAX Boards. The Auto FAX Detection feature allows most FAX calls to transfer to your FAX machine automatically.

The vast majority of FAX machines sold today have the ability to dial the number of the receiving FAX from memory, and then identify itself as a FAX machine with a tone (called CNG tone or AUTO-FAX tone). It will then continue to identify itself until the called FAX answers the call. When an ATX-250 is used at the receiving end, it can detect this FAX identification tone, and automatically transfer the call to the FAX machine on the receiving end, without ringing the telephone.

Occasionally, calls will come from a FAX machine without a FAX identification tone. This may happen if the calling person is using an older FAX machine, or dials the number manually using the FAX handset. In most applications, calls without this auto-FAX tone will be routed to your telephone system. The call can be manually transferred to the FAX machine by dialing [*] 2 (or another selected code) on your telephone keypad. Either the caller or the person who answers can transfer the call. See section 4.2.2 for details of operation.

If possible, ask people who send you FAX messages to program your number into their FAX machine's memory. This will allow FAX calls to always be processed automatically.

EQUIPMENT

2.2 COMPUTER MODEMS

Your ATX-250 is compatible with all dial-up MODEMS. Usually, MODEMS are attached to the DEVICE 2 connector of your ATX-250. Your ATX-250 will transfer incoming calls to your MODEM when the calling MODEM dials *2 (or another code, if re-programmed) after the call has been answered by your Versa-Link. The data protection feature prevents interruptions from other telephone equipment.

If your MODEM is only used for out-bound communication, you do not need to be concerned with the device selection code for the MODEM.

The device selection code for your MODEM is best dialed by the calling MODEM. For example, when calling into a MODEM attached to **DEVICE 2**, with the ATX-250 factory programming, the dialing command would be:

1 203 555 1234 , , * 2 , , * 2

The commas will generate pauses in the dialing MODEM. The number of pauses may need to be changed to allow enough time for the call to be switched through the telephone company, particularly if the calling MODEM is dialing long-distance.

The selectable device codes can be reconfigured to add security to any system. Your ATX-250 will restrict access to only those callers who dial the right device selection code. See section 6, **USER SELECTABLE FEATURES**, to change this code.

Some MODEMS cannot dial the [*] symbol. Therefore, if you plan to connect a computer MODEM, it is best to choose a device selection code for your computer that does not use the [*] symbol.

EQUIPMENT

2.3 TELEPHONES AND MULTI-LINE SYSTEMS

Your ATX-250 may be used with single and multi-line telephone equipment. Both tone-dialing and pulse-dialing equipment may be used with your ATX-250. See section 4.2.2 for restrictions when using pulse-dialing equipment.

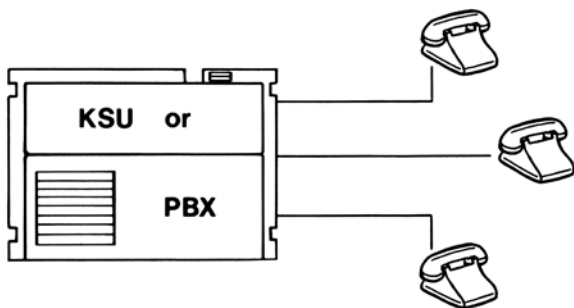

2.4 OTHER EQUIPMENT

Your ATX-250 is also compatible with Credit Authorization Terminals and Loop-Start dialup machines.

Your ATX-250 can also be used with answering machines and cordless phones.

2.5 "CALLER ID" SERVICE COMPATIBILITY

Your ATX-250 is now programmed to wait for and detect the transmission of "Caller ID" data. This function allows the calling party's phone number to appear on your "Caller ID" display unit before your ATX-250 routes the call to any device. This will allow "Caller ID" data to be displayed only on the line side. "Caller ID" data will not pass to the device ports. There is an upgrade which can be purchased to allow "Caller ID" data to pass to **DEVICE 1**.

There are many applications for your Versa-Link ATX-250. One unique advantage that Versa-Link gives you is the ability to change its operation as your business grows and your telephone needs change.

A few of the popular applications are described here.

3.1 ADDING A FAX MACHINE TO A VOICE LINE

This application allows your ATX-250 to automatically direct all Auto-dialing FAX calls to your FAX machine. All manually dialed FAX calls and all voice calls will be directed to your telephone. You can easily re-direct manually dialed FAX calls to your FAX by pressing 2 (or another code, if re-programmed) on your telephone.

As your business grows, you may want to make your FAX line a dedicated line. Your ATX-250 can still give you maximum utility of your phone lines. You may want to reconfigure your system to allow outgoing voice calls on this FAX line.

3.2 ADDING A MODEM TO A VOICE LINE

This application allows your ATX-250 to direct all voice calls to your telephone, and allow incoming computer MODEM calls to access your MODEM with the proper device code.

3.3 ADDING VOICE TO A FAX LINE

In this application, your ATX-250 will direct all incoming calls to your FAX machine when attached to the **DEVICE 1** port on your ATX-250. When your FAX is not in use, you will be able to use this line for telephone calls.

APPLICATIONS

3.4 ALLOWING TWO DATA DEVICES TO SHARE ONE TELEPHONE LINE

This application allows you to use two data devices, such as FAX, MODEM, Credit Authorization Terminal, etc. Normally, incoming calls will be directed to your FAX equipment. Data calls can easily reach your MODEM or other equipment by dialing the proper device selection code.

3.5 OTHER APPLICATIONS

Many configurations exist. For example, you can use your ATX-250 to:

- Screen incoming calls to your residence while allowing individuals with your selectable access code to bypass the answering machine.
- Allow two offices to share a single line with privacy.
- Allow two answering machines to be used together for stock quotations, dictation, daily results, sports scores, new real estate listings, etc.
- Allow remote cash register polling on an existing telephone line.

Your ATX-250 will route incoming calls to the proper equipment and prevent other devices from interfering with the ongoing communication.

4.1 OUTBOUND CALLS

Your ATX-250 will only allow one DEVICE port to access the telephone line at a time. For example, if you are sending or receiving a FAX, your telephones and extensions will be unable to interrupt the communication. If you pick up your phone or FAX and hear a busy signal, then another device is already using the line.

4.2 INCOMING CALLS

Incoming calls can be routed to your communications equipment in several ways:

- Calls may be automatically transferred to your FAX machine if the caller is a FAX that produces a FAX identification tone.
- Calls may be manually transferred by dialing touch tones from either end of the line or with pulse-dialing telephone equipment attached directly to your Versa-Link ATX-250. Tones may be entered by the calling party any time after the first ring.
- Calls can be transferred to your MODEM if the caller is an auto-dial MODEM that dials the proper device selection code.
- All calls may be automatically transferred to **DEVICE 2** after hours if CALL OPTIMIZER is activated.

4.2.1 Automatic FAX Transfer

Most FAX machines have the capability to dial the receiving FAX number from memory. When the number is dialed, an identification tone is produced every 3-1/2 seconds that allows call processing equipment, like your ATX-250, to identify the call as originating from a FAX.

When auto FAX tone detection is turned on, your ATX-250 will transfer these calls to **DEVICE 2**, where your FAX machine is normally connected.

NOTE: Many FAX machines allow both voice and FAX calls to be dialed manually from their keyboard. Also, some older FAX machines do not have auto-dialing capability. These machines may not always produce the necessary identification tone for automatic transfer. Manual dialed FAX calls will ring through to your telephone system and are easily transferred to your FAX by dialing [*] 2

It is possible for female voices to produce sounds of the same pitch as the FAX identification (CNG) tone. To avoid inadvertent transfers, your ATX-250 only monitors the initial stage of incoming calls for CNG tones.

OPERATION

4.2.2 Manual Transfer

To transfer calls to a selected device, enter the proper device selection code on your telephone (or other equipment). The factory settings are:

Device Selection Codes: **DEVICE 1** * 1
DEVICE 2 * 2

These device selection codes can be changed. See section 6.1 for detailed information on changing these codes.

The caller can manually transfer a call by using touch-tone telephones or other equipment.

The called party can manually transfer a call with either touch-tone or pulse-dialing equipment connected through the ATX-250. If you plan to manually transfer calls with a pulse-dialing telephone, choose device selection codes that do not use the * symbol.

WHEN TO ENTER A DEVICE SELECTION CODE

Device selection codes can be entered any time a call is in process. A caller can start entering device selection codes two seconds after hearing the first ring. This allows calls to be processed while the system is unattended.

CORRECTING MISTAKES

If a mistake is made entering a device selection code, stop entering tones for two seconds or longer, and re-enter the correct device selection code. If you are dialing on a pulse-dialing phone, wait five seconds or longer before reentering the code.

4.2.3 CALL OPTI-MIZER

Often it is desirable for all calls after hours and on weekends to go directly to the FAX machine or another automatic telephone device. This is especially useful when expanding a voice line with FAX and/or MODEM.

The primary application is for a company that has several incoming lines with rollover. Only one number is dialed by callers for voice traffic. If that line is busy, the telephone company "rolls over" the call to a second incoming line. If the second line is busy, the call "rolls over", and so on until the incoming call finds a line that is not busy.

The last line is published as the FAX number. Any incoming FAX call will ring in on this line. During the day, the last line is primarily used for voice, but may also be used for both incoming and outgoing FAX. However, at night, any call coming in on the last line is assumed to be a FAX. This is because all other lines would have to be busy for a voice call to come in on this line.

OPERATION

The CALL OPTI-MIZER feature will count the number of times the telephone (attached to **DEVICE 1**) rings, after an incoming call has been screened for Auto-dial FAX tones and device codes. If the phone is not answered in 5 rings (this number is selectable - see section 6.2), your ATX-250 will assume that the office is unattended, and that this call and all future calls should go to the FAX.

Your ATX-250 will immediately begin ringing this call to the FAX. (If your FAX has adjustable ring selection, set it to answer on the earliest possible ring).

At this time, your ATX-250 begins to operate in NIGHT FUNCTION. Now, incoming calls will ring your telephone system only 2 times (this number is selectable - see section 6.2), and then immediately ring the FAX. This will allow future incoming calls to go to the FAX sooner, with less chance of the caller hanging up before the FAX answers.

NIGHT FUNCTION is de-activated when you answer an incoming telephone call on this line within 2 rings or make an outgoing call on this line. Your ATX-250 will now operate in normal daytime function. This method of determining day/night/weekend is much simpler than using a clock or calendar which must continually be updated.

In the above example, a telephone system was connected to **DEVICE 1**, and a FAX to **DEVICE 2**. Of course, other devices may be substituted to fit your application.

IN SUMMARY, CALL OPTI-MIZER can be used when:

- (a) You want all calls after hours to go to your FAX or MODEM on DEVICE 2
 - and -
- (b) You DO NOT have an answering machine on the same incoming line as your FAX or (b) MODEM.

See section 6.2 to activate CALL OPTI-MIZER.

OPERATION

4.3 SUMMARY OF OPERATION

Your ATX-250 will answer incoming calls on the first ring and produce a simulated ring-back tone to the caller. Your ATX waits about six seconds longer before it begins to ring **DEVICE 1**. During this time the caller may manually transfer the call by dialing a device selection code. Your ATX-250 is also screening the call for auto FAX tones.

If no auto FAX tone is detected, and if no device selection codes are entered, your ATX-250 will begin to ring the equipment attached to **DEVICE 1**. Once connected, your ATX-250 will isolate equipment attached to the other device ports for the duration of the call.

The call can be manually transferred at any time by either party. There is no limit to the number of times the same call can be transferred. During transfers, the caller is put on hold, and hears a ringback signal while the selected device is being rung. All devices that are not selected are disconnected from the telephone line. A busy signal is conveniently provided to all non-selected devices.

When the line is not in use, any device can place an outgoing call. During this time, all other devices are disconnected from the incoming line.

If the caller is dialing long distance, charges begin when your ATX-250 answers incoming calls.

RINGING DEVICES

When your ATX-250 is ringing a device, it will attempt eight rings to that device. If the selected device does not answer within this period, your ATX-250 will disconnect the call and restore all devices to their original condition.

TRANSFER DEFEAT

Dialing "80" on an inbound call will cause your ATX-250 to ignore all device selection codes for the rest of that call. This is useful if you are calling into an answering machine to get your messages. This will prevent tones that may be on your incoming message tape from accidentally transferring your call.

The following section covers installation of your Versa-Link ATX-250 in various applications.

NOTE: You may want to call a local telephone service company to install the necessary jacks between the telephone company's line and your internal wiring.

5.1 INITIAL CHECK-OUT

Your ATX-250 shipping carton should contain the following equipment:

- Your Versa-Link ATX-250
- An AC wall transformer with cord
- One modular telephone cable

Plug the 12 Volt AC wall transformer into an electrical outlet (110 Volt AC, 50-60 Hz) and plug its power cord into the power connector on the back of your ATX-250. The **LED** indicator on the front of your ATX-250 should now be lit, showing that power is on and the ATX-250 is operating.

5.2 CONNECTING TO THE PHONE LINE

WHAT LINE DO I USE?

Locate and identify the telephone line to which you plan to attach your ATX-250. If you are using a multi-line telephone system with rollover, use the last line in the rollover sequence.

WHERE DO I CONNECT MY ATX-250?

Locate a point on the line between the telephone company and all existing telephone equipment and extensions attached to this line. Disconnect all telephone equipment and extensions from the telephone line. They will later be re-connected to the telephone line

THROUGH your ATX-250. You may need to install RJ-11 jacks to facilitate installation of your ATX-250.

IMPORTANT: One function of your ATX 250 is to receive incoming calls and then distribute them to the proper equipment. For this reason it is VERY important that your ATX-250 be installed ahead of all existing telephone extensions and equipment.

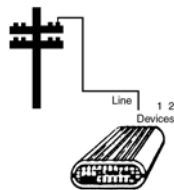

Attach the incoming telephone line to the **LINE** connector on the back of your ATX-250. The ATX-250 should now be the only device connected to this telephone line.

5.3 RE-CONNECTING YOUR TELEPHONE SYSTEM

If you are using this line for voice communication, you will need to reconnect your telephone system THROUGH THE ATX-250. First, you will want to determine what type of phone system you have.

INSTALLATION

5.3.1 SINGLE LINE TELEPHONES

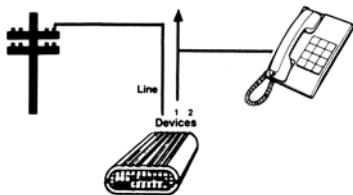

Attach your telephone system to the **DEVICE 1** connector on the back of your ATX-250. If you have only one phone with no extensions, you can connect the phone by plugging it into the **DEVICE 1** connector on your ATX-250. If you have extensions, attach the **DEVICE 1** connector to one of the extension jacks. This will re-connect all the extensions.

5.3.2 MULTI-LINE TELEPHONES

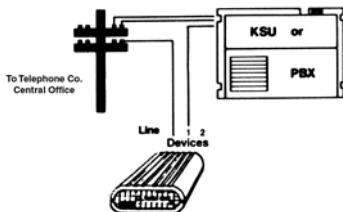

If you are using a multi-line Key system, attach your KSU telephone input for the selected line to the **DEVICE 1** connector on the back of your ATX-250.

NOTE: Your ATX-250 is not designed to operate at a station port of a KSU. It will only operate on the trunk side of a key system.

If you are using a two-line feature phone system with no controller (called an RJ-14 system), connect the telephone cable attached to the selected line of your dual line phone system to the **DEVICE 1** connector on the back of your ATX-250.

5.3.3 PBX (Private Branch Exchange)

Your ATX-250 can be used at a station extension of any PBX. It can also be used on the trunk side of most loop-start PBX's. Whether you are installing your ATX-250 on a station extension or on a PBX trunk, first verify that the circuit is compatible by testing it with a single-line telephone. If you are unable to get a dial tone, the line is not compatible.

WARNING: Improper connections to PBX extensions and trunks can cause damage to telephone equipment. If you are in doubt, contact your local telephone service company.

Products are available to allow use of loop-start equipment on a ground-start PBX trunk. Contact your local telephone service company or our experts here at Multi-Link.

5.4 ATTACHING OTHER DEVICES (FAX, MODEM, ETC.)

When you attach your FAX, computer MODEM, credit terminal, or other equipment, set the equipment to answer incoming calls on the first or second ring, if possible.

INSTALLATION

How you attach your data equipment depends entirely on what you want your system to do. Some of the most popular applications are listed below:

5.4.1 ADDING FAX TO A VOICE LINE

When adding FAX to a voice line, attach your FAX to the **DEVICE 2** connector on the back of your ATX-250. See your installation manual for details.

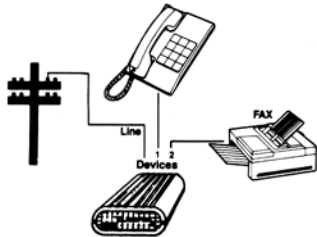

You should enable auto FAX tone detection. Configuration switch 6 should be set to the “up” position. This is the factory setting.

If necessary, change the configuration switch on the back of your ATX-250. Unplug the ATX-250 power cord for about 2 seconds and re-connect it to activate the new settings.

In addition, you may also want to turn on CALL OPTI-MIZER if you are using your ATX-250 on a multi-line system. See section 4.2.3 for details.

5.4.2 ADDING VOICE TO A FAX LINE

If you are expanding the use of your FAX

line you will want to move your telephone system to the **DEVICE 2** connector and attach your FAX machine to **DEVICE 1**. This will allow all incoming calls to go directly to your FAX machine. Outbound calls can be made as usual, and incoming calls are possible using manual transfer.

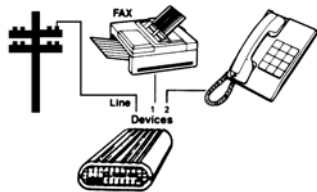

You will want to disable auto FAX tone detection. Set the configuration switch position 6 to the “down” position.

Unplug the power cord from your ATX-250 for about 2 seconds and re-connect it to activate the new switch settings.

5.4.3 Allowing Two Data Devices to Share One Line

If you are using FAX, attach your FAX machine to the **DEVICE 1** connector on the back of your ATX-250. Attach your other data device to the **DEVICE 2** connector.

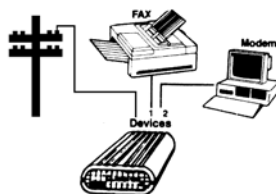

INSTALLATION

If you are not using FAX, choose the data device that most of your incoming calls should go to. Attach this device to the **DEVICE 1** connector on the back of your ATX-250. Attach the other data device to the **DEVICE 2** connector.

If you are not using FAX, or if your FAX is attached to **DEVICE 1**, you should disable auto FAX detection. Set the configuration switch position 6 to the "down" position.

Unplug the power cord from your ATX-250 for about 2 seconds and re-connect it to activate the new switch settings.

5.4.4 ADDING AN ANSWERING MACHINE

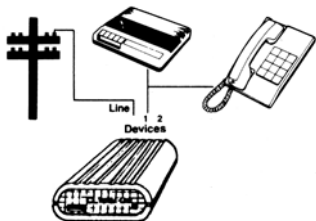

If you use an answering machine, attach it to the same connector that your telephone system is attached to. You may either connect your telephone system through your answering machine, if a connector is provided on the answering machine for that purpose, or you may need to use a multi-outlet Y-adapter.

You may also want to leave instructions on the outgoing message to instruct callers on how to access your data equipment. If you have a FAX attached to **DEVICE 2**, remember to give out your device selection code for access to your

FAX, so that callers with manually dialed FAX machines can send you messages while you are not there. A sample message might be:

"Hello, this is _____. If you would like to leave a FAX message, press star-two to ring our FAX machine. If you would like to leave a voice message, please begin speaking after the tone. Thank you for calling."

5.5 CONFIGURING THE ATX-250 TO YOUR APPLICATION

Depending on your application, you may want to change the factory settings of the configuration switches or change the device selection codes.

For a detailed description of all the operational features, and step-by-step information on how to select them, see section 6, **USER SELECTABLE FEATURES**.

5.6 GENERAL RULES OF INSTALLATION

When installing your ATX-250 there are three general principles to keep in mind:

5.6.1

Your ATX-250 must be the only device directly connected to the telephone company's incoming line.

There cannot be any extensions or data devices connected in parallel with your ATX-250 on this line. All extensions and data devices must be connected to one of the DEVICE ports on the back of your ATX-250.

INSTALLATION

For example, if you connect your ATX-250 in the following way, it will not function properly:

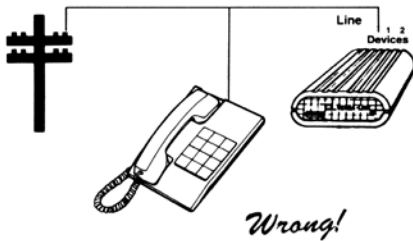

Ringling will be heard in the background if a call is answered by one of the extension phones. Also, your ATX-250 cannot prevent an extension phone from being lifted and interrupting a FAX call.

For the same reason, off-premise extensions (OPX), including answering services located away from your building, are not compatible with your ATX-250. Do not install an ATX-250 if you have an OPX.

5.6.2

Your ATX-250 is intended for use with standard modular RJ-11 jacks.

Many key system station jacks look the same, but are not wired for the RJ-11 standard. In addition, some ground-start PBX trunks are incompatible. Neither an ATX-250 nor a FAX machine will operate if connected to this point.

The general rule is: if a SINGLE-LINE telephone will work on the connector, your ATX-250 will work. You can usually use a telephone line tester to verify that the jack is wired for RJ-11.

5.6.3

Manual transfers are accomplished by entering touch-tones or dial pulses.

Some multi-line key systems do not allow tone or dial pulse generation on incoming calls. To determine if the key system is capable of manually transferring an incoming call, call the line on which you wish to install your ATX-250 from another location, and listen to determine if the person who answers can dial touch-tones.

Pulse-dialing telephone equipment and some key systems do not generate the * or # signals. You can overcome this limitation by changing the ATX-250 device selection codes to new codes that do not contain * or #. See section 6.1 to change device selection codes.

On a few key systems, dialing * # will unlock the key pad to once a ain dial touch-tones. Try dialing * # * 2, for example, to manually transfer to your FAX machine.

On some key systems that do not allow tone generation on inbound calls, you can fool the telephone system into thinking it is making an outbound call by pressin the "FLASH" key, and then dialing * 2. To keep from hanging up the caller, activate the "Protected Hook Flash" feature. See section 6.3.

USER SELECTABLE FEATURES

6

Your Versa-Link ATX-250 can be used in a wide variety of applications by changing the selectable features.

The following features are set with the configuration switches located on the back of your ATX-250:

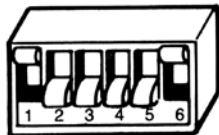

DEVICE CODE SELECTION
CALL OPTI-MIZER
PROTECTED HOOK FLASH
FAX TONE DETECTION





Use a pen or other small instrument to make changes to the configuration switches.

IMPORTANT: Configuration switch changes are not activated until AC power is re-applied. Therefore, unplug and reconnect the AC power cord after making any configuration switch changes to enter these settings into memory.

6.1 DEVICE CODE SELECTION

Your ATX-250 analyzes incoming calls for touch-tones and analyzes your equipment for both pulse-dial and touch-tone device selection codes.

There are four different sets of device selection codes that your ATX-250 will recognize. Set the configuration switches 1 and 2 according to the following table:

CONFIGURATION SWITCHES		DEVICE 1 CODE	DEVICE 2 CODE
1	2		
		* 1	* 2
		2 1	2 2
		* 1	* 2 OR * 3
		2 1	5 6 3 2

Remember to unplug and re-connect the AC power after changing the configuration switches.

The third set is useful for compatibility with other Versa-Link products. The fourth set allows extra security for equipment attached to "DEVICE 2".

If your equipment is pulse-dial only, you cannot use the codes containing the * symbol.





USER SELECTABLE FEATURES

6.2 CALL OPTI-MIZER

CALL OPTI-MIZER is useful if you want all incoming calls to go to **DEVICE 2** when your office is unattended. See section 4.2.3 for a detailed description.

When using CALL OPTI-MIZER, there are three choices for the parameters that determine when a call is sent to **DEVICE 2**. CALL OPTI-MIZER can also be completely disabled. Set the configuration switches 3 and 4 according to the following table:

Remember to unplug and re-connect the AC power after changing the configuration switches.

CONFIGURATION SWITCHES 3 4	NO. OF RINGS TO ACTIVATE NIGHT FUNCTION	NO. OF RINGS TO DEVICE 1 IN NIGHT FUNCTION
	5	2
	4	2
	3	1
	(CALL OPTI-MIZER IS OFF)	(CALL OPTI-MIZER IS OFF)

6.3 PROTECTED HOOK FLASH

Some key tone telephone systems do not allow tone generation on an inbound call. On these systems, manual transfers can still be accomplished by fooling the telephone system into thinking it is making an outbound call. This is done by pressing the "**FLASH**" key on the telephone, and then dialing the device code for **DEVICE 2**.

For example, if your FAX is connected to **DEVICE 2**, and the device selection code for **DEVICE 2** is [*] 2, calls can be manually transferred to the FAX by pressing **FLASH** and then [*] 2.

To prevent the caller from being hung up when the **FLASH** key is pressed, you will want to activate Protected Hook Flash. This will place the call on hold while the flash button momentarily disconnects the line. Protected Hook Flash cannot be used if your phone is pulse-dial or if this line has "call waiting".

Configuration switch 5 is used to select Protected Hook Flash. Remember to unplug and re-connect the AC power after changing the configuration switch.

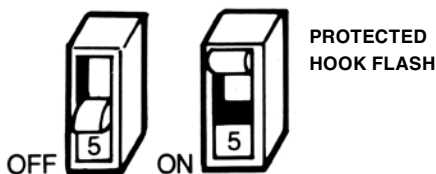

USER SELECTABLE FEATURES

6.4 FAX TONE DETECTION

If you connect a FAX machine to your network, you will need to tell your ATX-250 which **DEVICE** port it is on. This allows auto-dial FAX calls to be transferred to your FAX machine automatically.

If you adding FAX to a voice line, connect the FAX to **DEVICE 2**.

If you are expanding a FAX line, connect the FAX to **DEVICE 1**.

Configuration switch 6 is used to select FAX tone detection. Remember to unplug and re-connect the AC power after changing the configuration switch.



6.5 SELECTIVE RINGING FEATURE WITH TRANSFER

The "Selective Ringing" feature on your ATX-250 is designed to be used in conjunction with the "distinctive ring" service offered by your local telephone company.

In the "selective ring" mode, your ATX-250 will detect the multiple ring patterns associated with each telephone number

and route the call to the intended phone device. Switching is completely transparent to the caller.

"Selective Ringing" can be enabled by simply placing all DIP Switches in, the up position as indicated below-and recycling power.

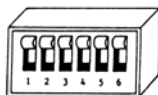

IMPORTANT: Configuration switch changes are not activated until AC power is re-applied. Therefore unplug and re-connect the AC power cord after making any configuration switch changes to enter these settings into memory.

Manual Transfer - In "Selective Ringing" mode your ATX-250 has the same basic manual transfer capability as with normal function. To transfer calls to a selected device, enter the proper device selection code on your telephone key pad (or other equipment). The factory settings are:

Device Selection Codes

DEVICE 1 * 1 or 21
DEVICE 2 * 2 or 22

6.6 FACTORY SETTINGS

When your ATX-250 was shipped to you, it was programmed with the following settings:

DEVICE SELECTION CODES	DEVICE 1	* 1
	DEVICE 2	* 2 OR * 3
CALL OPTI-MIZER	OFF	
PROTECTED HOOK FLASH	OFF	
FAX TONE DETECTION	ON	

USER SELECTABLE FEATURES

To restore the original factory settings, set the configuration switches (located on the back of your ATX-250) according to the chart below. Set switches 1 and 6 UP, and switches 2,3,4, and 5 DOWN.

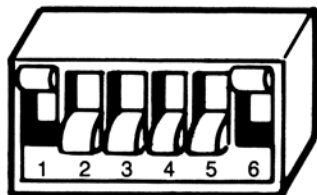

Unplug the AC power cord on your ATX-250 for about 2 seconds and re-connect the power to activate the new settings.

Before you contact Multi-Link about a question, please read this section. If you are experiencing a problem, you may be able to quickly solve it yourself.

COMMONLY ASKED QUESTIONS

WHY DO SOME FAX CALLS GO TO MY TELEPHONE?

Sometimes FAX calls originate from equipment that does not identify itself as a FAX machine. You can manually transfer the call by dialing the device selection code for your FAX (factory set to [* 2]). See section 2.1. Activating CALL OPTI-MIZER may eliminate this problem at night. See section 4.2.3 for details.

Also, you may need to change auto-FAX tone detection. See section 6.4.

WHY DO I SOMETIMES GET A BUSY SIGNAL WHEN I PICK UP MY PHONE?

The data protection feature of your ATX-250 disconnects your telephone when your FAX or MODEM is in use. Wait for your FAX or MODEM to finish, and try your telephone again.

AFTER I CHANGE THE CONFIGURATION SWITCHES, WHY DOES THE ATX-250 NOT CHANGE ITS OPERATION?

Any time you change the configuration switches on the back of your ATX-250 you must unplug its power cord for about two seconds to activate the new settings.

WHY DOES MY ATX-250 REPEATEDLY CLICK-CLICK WHEN I PICK UP THE LINE?

If you cannot get a dial tone, and only hear a click-click every two seconds or so, the ATX-250 does not have a good connection to the phone company. Check your installation and wiring for loose or open connections. Connect a single-line telephone directly to the incoming line. Check for dial tone and proper operation. A dead line should be reported to your telephone company.

WHY DOES MY FAX ANSWER ALL INCOMING CALLS?

Your ATX-250 may not be getting any power. Check the LED indicator on the front panel. If the LED is not lit, check the power connector, the AC adaptor, and the AC power source.

I ENTER [* 2] ON MY PHONE TO TRANSFER AN INCOMING CALL TO MY FAX.

WHY DOES THE CALL NOT TRANSFER?

Some multi-line key telephones will not generate tones after receiving an incoming call. You may need to activate the Protected Hook Flash feature. Refer to section 6.3.

WHY DO I SOMETIMES HEAR RINGING IN THE BACKGROUND WHEN I ANSWER THE PHONE?

Your ATX-250 may not be installed as the only device directly connected to the telephone line. To determine this, disconnect the cord from the **LINE** jack of your ATX-250. If you can get a dial tone on any of your telephones, your installation is not correct.

FCC REGISTRATION & LIMITED WARRANTY

FCC REGISTRATION

This equipment complies with Part 68 of the FCC rules. On the bottom of this equipment is a label that contains, among other information, the FCC Registration Number and Ringer Equivalence Number (REN) for this equipment. You must, upon request, provide this information to your telephone company.

The REN is useful to determine the quantity of devices you may connect to your telephone line and still have all of those devices ring when your telephone number is called. In most, but not all areas, the sum of the RENs of all devices connected to one line should not exceed five (5.0). To be certain on the number of devices you may connect to your line, as determined by the REN, you should contact your local telephone company to determine the maximum REN for your calling area.

If your telephone equipment causes harm to the telephone network, the telephone company may discontinue your service temporarily. If possible, they will notify you in advance. But if advance notice isn't practical, you will be notified as soon as possible. You will be informed of your right to file a complaint with the FCC. Your telephone company may make changes in its facilities, equipment, operations or procedures that could affect the proper functioning of your equipment. If they do, you will be notified in advance to give you an opportunity to maintain uninterrupted telephone service.

If you experience trouble with this telephone equipment, please contact your Versa-Link dealer or Multi-Link, Inc. for information on obtaining service or repairs. The telephone company may ask that you disconnect this equipment from the network until the problem has been corrected or until you are sure that the equipment is not malfunctioning.

This equipment may not be used on coin service provided by the telephone company, and is not intended for use with party line service. This equipment is intended for use only on loop-start service, and will not operate on a groundstart central office line.

LIMITED WARRANTY

We warrant that if this Versa-Link ATX-250 product, manufactured by Multi-Link, Inc. and purchased by you, proves to be defective in material or workmanship, we will provide without charge, for a period of two (2) years, the labor and the parts necessary to remedy any such defect. Warranty period commences on the date of purchase by the original retail consumer.

The duration of any implied warranty of merchantability, fitness for a particular purpose, or otherwise, on this product shall be limited to the duration of the applicable express warranty set forth above. In no event shall we be liable for any loss, inconvenience or damage whether direct, incidental, consequential or otherwise resulting from breach of any express or implied warranty, of merchantability, fitness for a particular purpose, or otherwise with respect to this product, except as set forth herein. Some states do not allow limitations on how long an implied warranty lasts and some states do not allow the exclusion or limitation of incidental or consequential damages, so the above limitations or exclusion may not apply to you.

To obtain service under this warranty, you must present or send your ATX-250 product, together with a copy of the retail seller's original bill of sale, your charge or credit receipt, or other satisfactory proof of the date of the original retail purchase of the product, to any of the Versa-Link authorized service stations. A list of the Versa-Link authorized service stations can be obtained from your Versa-Link dealer or from Multi-Link, Inc.

Any postage, insurance or shipping cost incurred in presenting or sending your ATX-250 product for service is your responsibility. However, Multi-Link will pay for all return freight expenses.

The AC adaptor used with this product is covered under this warranty. This warranty does not cover damage which results from accident, misuse, abuse, improper line voltage, fire, flood or damage resulting from repairs or alterations performed other than by Versa-Link authorized service stations. This warranty gives you specific legal rights, and you may also have other rights which vary from state to state.

TECHNICAL SPECIFICATIONS

Input power requirements:

At AC Transformer: 110 - 125 Volts AC Only; 50-60 Hz

At power jack on ATX-250: 12-15 Volts AC only

Power consumption Idle: 3 Watts

Ringling a device: 6-11 Watts

CO Interface: Ren 1.1 B

DOC (Canada) Load No. 83

Input ring detection: 40-150 Volts AC; 15-68 Hz

DEVICE Interface:

Battery: Nominal - 45.5 Volt DC to devices 1 and 2

Off-hook detection: 3-150 ma

Ringer frequency: 33 Hz Pseudo-sinewave

Ringling no load: Approximately 145.6 Volts AC

Ringling 8000 ohm impedance

(REN 1.0): Approximately 116 VAC

Ringling 4000 ohm impedance

(REN 2.0): Approximately 98 VAC

Ringling 2667 ohm impedance

(REN 3.0): Approximately 83 VAC

Ringling short circuit: current limited to 110 ma with ring trip. *(impedances less than 2667 ohms not recommended)*

SERVICE INFORMATION

Your machine has been registered with the Federal Communications Commission, and under this program, in the event of equipment malfunction, all repairs will be performed by Multi-Link, Inc. or a warranty repair center that we have authorized. The owner is restricted from performing any maintenance operation other than those specified within this instruction manual.

If you require service, please contact your Versa-Link dealer or Multi-Link, Inc.

Multi-Link, Inc.
225 Industry Road
Nicholasville, KY 40356
(859) 885-6363
FAX (859) 885-6619
www.multi-link.net

TEMPLATE FOR PLACEMENT OF MOUNTING SCREWS

On the bottom of each ATX-250 are rubber feet which keep the device from sliding if placed on a table or the floor. Beneath two of the feet (on right side, if you face the front panel of the cabinet) are holes which allow you to mount the cabinet on a wall or baseboard. Screws for mounting have been provided. Please use this template for best results.

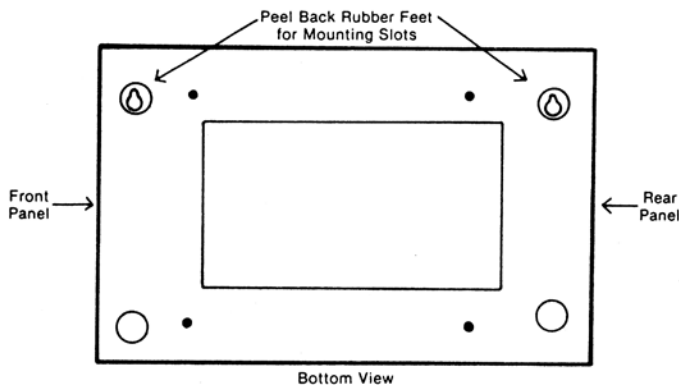

After properly placing and driving the mounting screws, be sure that the shaft space between the wall surface and inside screwhead is approximately $3/16"$. This insures that the wall unit will fit snugly on both screws and internal electronics will be protected from screwheads.

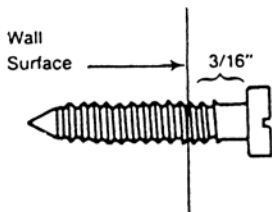

The Versa-Link ATX-250 contains patented and otherwise proprietary circuits and software algorithms. This owner's manual describes the operation and function of some of these circuits and algorithms. Unauthorized duplication of this manual is a violation of U.S. and other copyright laws, and unauthorized use of all or part of this manual may result in patent infringement. Therefore, THIS MANUAL IS TO BE USED ONLY WITH OR AS A MARKETING TOOL FOR THE VERSA-LINK ATX-250. Duplication of all or part of this manual without the permission of Multi-Link, Inc. is prohibited.

Printed in the U.S.A.
Multi-Link, Inc.
225 Industry Road
Nicholasville, KY 40356
(859) 885-6363
FAX (859) 885-6619